

FLUID POWER GRAPHIC SYMBOLS

ANSI Y32.10 GRAPHIC SYMBOLS

1. Introduction

1.1 General

Fluid power systems are those that transmit and control power through use of a pressurized fluid (liquid or gas) within an enclosed circuit.

Types of symbols commonly used in drawing circuit diagrams for fluid power systems are Pictorial, Cutaway, and Graphic. These symbols are fully explained in the USA Standard Drafting Manual (Ref. 2).

1.1.1 Pictorial symbols are very useful for showing the interconnection of components. They are difficult to standardize from a functional basis.

1.1.2 Cutaway symbols emphasize construction. These symbols are complex to draw and the functions are not readily apparent.

1.1.3 Graphic symbols emphasize the function and methods of operation of components. These symbols are simple to draw. Component functions and methods of operation are obvious. Graphic symbols are capable of crossing language barriers, and can promote a universal understanding of fluid power systems.

Graphic symbols for fluid power systems should be used in conjunction with the graphic symbols for other systems published by the USA Standards Institute (Ref. 3-7 inclusive).

1.1.3.1 Complete graphic symbols are those, which give symbolic representation of the component and all of its features pertinent to the circuit diagram.

1.1.3.2 Simplified graphic symbols are stylized versions of the complete symbols.

1.1.3.3 Composite graphic symbols are an organization of simplified or complete symbols. Composite symbols usually represent a complex component.

1.2 Scope and Purpose

1.2.1 Scope – This standard presents a system of graphic symbols for fluid power diagrams.

1.2.1.1 Elementary forms of symbols are:

Circles Rectangles Arcs Dots

Squares Triangles Arrows Crosses

Symbols using words or their abbreviations are avoided. Symbols capable of crossing language barriers are presented herein.

Component function rather than construction is emphasized by the symbol.

1.2.1.4 The means of operating fluid power components are shown as part of the symbol (where applicable).

1.2.1.5 This standard shows the basic symbols, describes the principles on which the symbols are based, and illustrates some representative composite symbols. Composite symbols can be devised for any fluid power component by combining basic symbols.

Simplified symbols are shown for commonly used components.

1.2.1.6 This standard provides basic symbols, which differentiate between hydraulic and pneumatic fluid power media.

1.2.2 Purpose

1.2.2.1 The purpose of this standard is to provide a system of fluid power graphic symbols for industrial and educational purposes.

1.2.2.2 The purpose of this standard is to simplify

design, fabrication, analysis, and service of fluid power circuits.

1.2.2.3 The purpose of this standard is to provide fluid power graphic symbols, which are internationally recognized.

1.2.2.4 The purpose of this standard is to promote universal understanding of fluid power systems.

2. Symbol Rules

2.1 Symbols show connections, flow paths, and functions of components represented. They can indicate conditions occurring during transition from on flow path arrangement to another. Symbols do not indicate construction, nor do they indicate values, such as pressure, flow rate, and other component settings.

2.2 Symbols do not indicate locations of ports, direction of shifting spools, or positions of actuators on actual components.

2.3 Symbols may be rotated or reversed without altering their meaning except in the cases of: a.) Lines to Reservoir, 4.1.1; b.) Vented Manifold, 4.1.2.3; c.) Accumulator, 4.2.

2.4 Line Technique

Keep line widths approximately equal. Line width does not alter meaning of symbols.

2.4.1 Solid Line - Main 

2.4.2 Dash Line – Pilot 
(Pilot line for control)

2.4.3 Dotted Line 
(Exhaust or Drain Line)

2.4.4 Center Line 
(Enclosure Outline)

2.4.5 Sensing Line – Same as line which it connects.

2.4.6 Lines Crossing (The intersection is not necessarily at a 90° angle.)

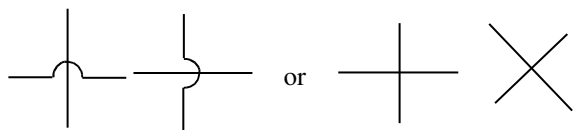

2.4.7 Lines Joining

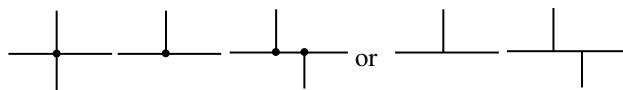

2.5 Basic symbols. May be shown any suitable size. Size may be varied for emphasis or clarity. Relative sizes should be maintained. (As in the following example.)

2.5.1 Circle and Semi-Circle



2.5.1.1 Large and small circles may be used to signify that one component is the “main” and the other the auxiliary.

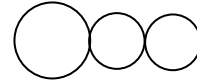

2.5.2 Triangle



2.5.3 Arrow



2.5.4 Square

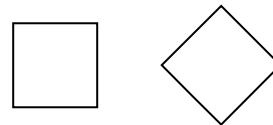

Rectangle

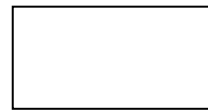

2.6 Letter combinations used as parts of graphic symbols are not necessarily abbreviations.

2.7 In multiple envelope symbols, the flow condition shown nearest an actuator symbol takes place when that control is caused or permitted to actuate.

2.8 Each symbol is drawn to show normal, at rest, or neutral condition of component unless multiple diagrams are furnish shown various phases of circuit operation. Show an actuator symbol for each flow path condition possessed by the component.

2.9 An arrow through a symbol at approximately 45 degrees indicates that the component can be adjust or varied.

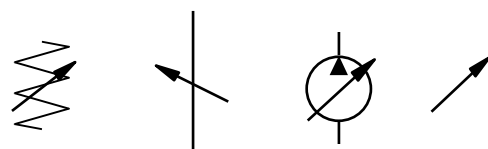

2.10 An arrow parallel to the short side of a symbol, within the symbol, indicates that the component is pressure compensated.

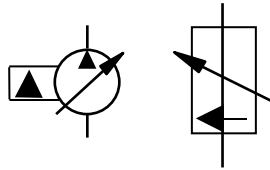

2.11 A line terminating in a dot to represent a thermometer is the symbol for temperature cause or effect



See Temperature Controls 7.9. Temperature indicators and Recorders 9.1.2 and Temperature Compensation 10.16.3 and 10.16.4.

2.12 External ports are located where flow lines connect to basic symbol, except where component enclosure symbol is used.

External ports are located at intersections of flow lines and component enclosure symbol when enclosure is used, see Section 11.

2.13 Rotating shafts are symbolized by an arrow which indicates direction of rotation (assume arrow on near side of shaft).

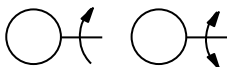

3. Conductor, Fluid

3.1 Line, Working (main)



3.2 Line, Pilot (for control)



3.3 Line, Exhaust and Liquid Drain

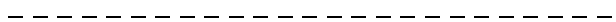

3.4 Line, sensing, etc. such as gauge lines shall be drawn the same as the line to which it connects.

3.5 Flow Direction of

3.5.1 Pneumatic

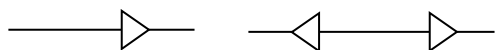

3.5.2 Hydraulic

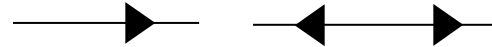

3.6 Line, Pneumatic (Outlet to Atmosphere).

3.6.1 Plain orifice, unconnectable



3.6.2 Connectable orifice (e.g. Thread)

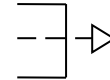

3.7 Line with Fixed Restriction



3.8 Line, Flexible

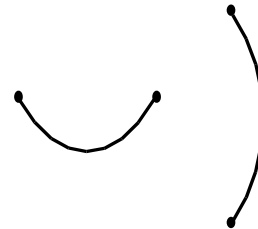

3.9 Station, Testing, measurement, or power take-off.

3.9.1 Plugged port.

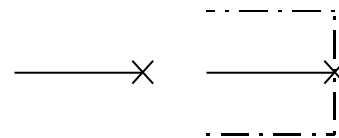

3.9.2 Quick Disconnect

3.9.3 Without Checks

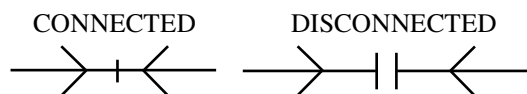

3.9.4 With Two Checks

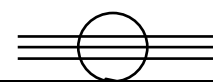

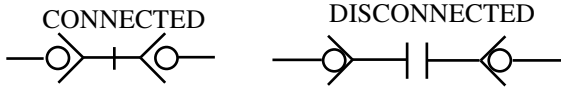

3.9.5 With One Check

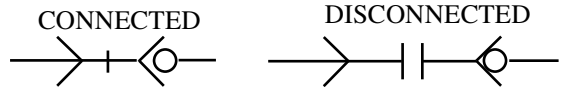

3.11 Rotating Coupling

4. Energy Storage and Fluid Storage

4.1 Reservoir



Note: Reservoirs are conventionally drawn in the horizontal plane. All lines enter and leave from above.

4.1.1 Reservoir with Connecting Lines Above Fluid Level

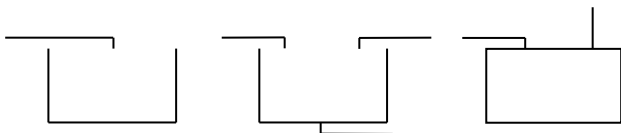

Below Fluid Level

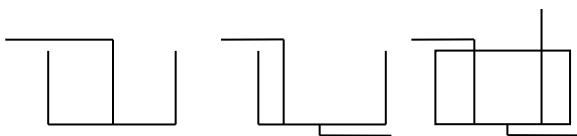

Show line entering or leaving below reservoir only when such bottom connection is essential to circuit function.

4.1.2 Simplified symbol



The symbols are used as part of a complete circuit. They are analogous to the ground symbol of electrical diagrams.

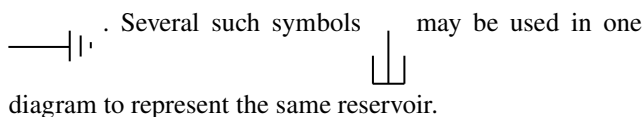

4.1.2.1 Below Fluid Level



4.1.2.2 Above Fluid Level

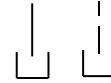

(The return line is drawn to terminate at the upright legs of the tank symbol.)

4.1.2.3 Vented Manifold

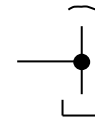

4.2 Accumulator



4.2.1 Accumulator, Spring Loaded



4.2.2 Accumulator, Gas Charged



4.2.3 Accumulator, Weighted



4.3 Receiver



4.4 Energy Source (Pump, Compressor, Accumulator, etc.)

This symbol may be used to represent a fluid power source which may be a pump, compressor, or another associated system.

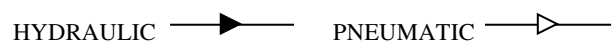

5.1 Heat Exchanger

5.1.1 Heater

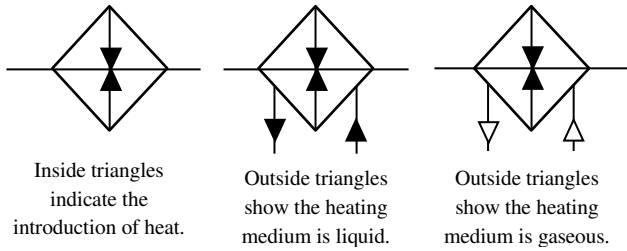

5.1.2 Cooler

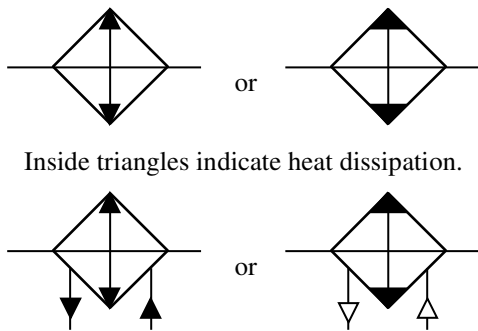

(Corners may be filled in to represent triangles.)

5.1.3 Temperature Controller (The temperature is to be maintained between two predetermined limits.)

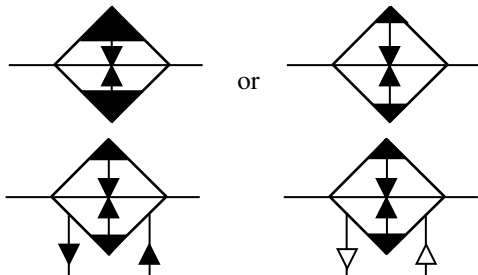

5.2 Filter – Strainer

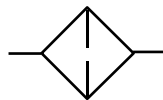

5.3 Separator

5.3.1 With Manual Drain

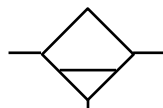

5.3.2 With Automatic Drain

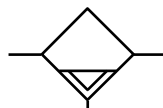

5.4 Filter – Separator

5.4.1 With Manual Drain

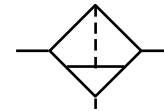

5.4.2 With Automatic Drain

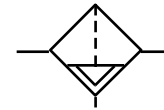

5.5 Desiccator (Chemical Dryer)

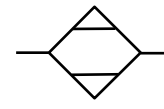

5.6 Lubricator

5.6.1 Less Drain

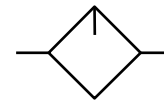

5.6.2 With Manual Drain

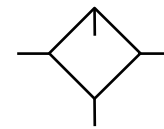

6. Linear Devices

6.1 Cylinders, Hydraulic and Pneumatic

6.1.1 Single Acting

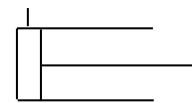

6.1.2 Double Acting

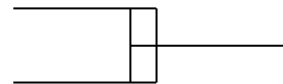

6.1.2.1 Single End Rod

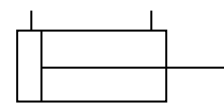

6.1.2.2 Double End Rod

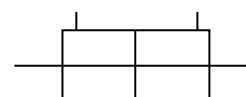

6.1.2.3 Fixed Cushion, Advance and Retract



6.1.2.4 Adjustable Cushion, Advance Only

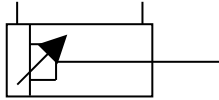

6.1.2.5 Use these symbols when diameter of rod compared to diameter of bore is significant to circuit function.



NON CUSHION

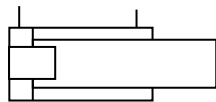

CUSHION, ADVANCE AND RETRACT

6.2 Pressure Intensifier

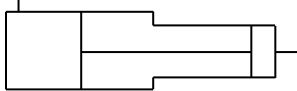

6.3 Servo Positioner (Simplified)

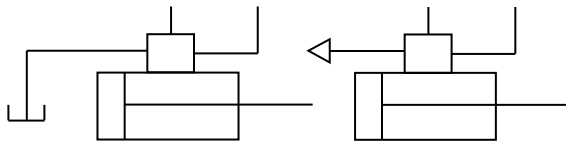

Hydraulic

Pneumatic

6.4 Discrete Positioner

Combine two or more basic cylinder symbols.

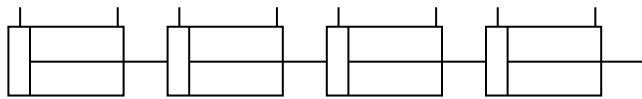

7. Actuators and Controls

7.1 Spring

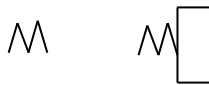

7.2 Manual



(Use as general symbol without indication of specific type; i.e., foot, hand, leg, arm.)

7.2.1 Push Button

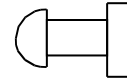

7.2.2 Lever

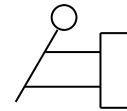

7.2.3 Pedal or Treadle

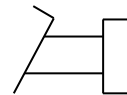

7.3 Mechanical

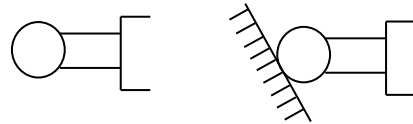

7.4 Detent

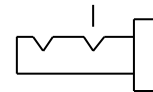

(Show a notch for each detent in the actual component being symbolized. A short line indicates which detent is in use.) Detent may, for convenience, be positioned on either end of symbol.

7.5 Pressure Compensated

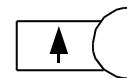

7.6 Electrical

7.6.1 Solenoid (Single Winding)

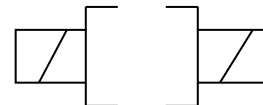

7.6.2 Reversing Motor

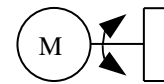

7.7 Pilot Pressure

7.7.1 Remote Supply

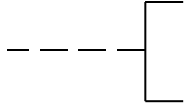

7.7.2 Internal Supply

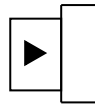

7.7.3 Actuation by Released Pressure

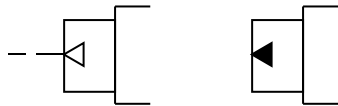

By Remote Exhaust By Internal Return

7.7.4 Pilot Controlled, Spring Centered

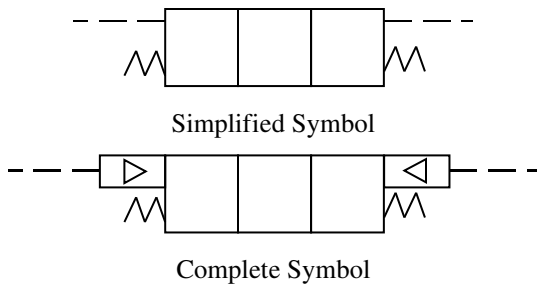

Simplified Symbol

Complete Symbol

7.7.5 Pilot Differential

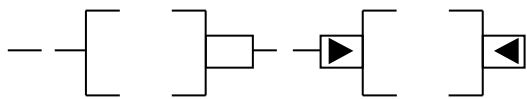

Simplified Symbol

Complete Symbol

7.8 Solenoid Pilot

7.8.1 Solenoid or Pilot

External Pilot Supply

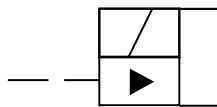

Internal Pilot Supply and Exhaust

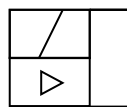

7.8.2 Solenoid and Pilot

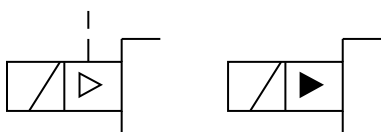

7.9 Thermal – A mechanical device responding to thermal change.

7.9.1 Local Sensing

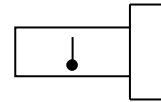

7.9.2 With Bulb for Remote Sensing

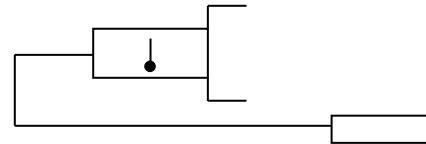

7.10 Servo

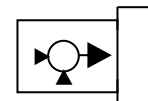

(This symbol contains representation for energy input, command input, and resultant output.)

7.11 Composite Actuators (and, or, and/or)

Basic . . One signal only causes the device to operate

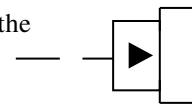

And . . ; One signal and a second signal both cause the device to operate.

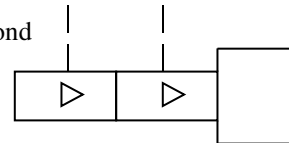

Or . . One signal or the other signal causes the device to operate.

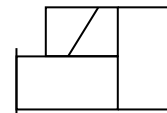

And/Or . . The solenoid and the pilot or the manual override alone causes the device to operate.

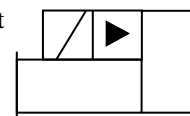

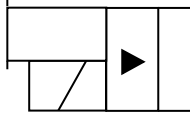

The solenoid and the pilot or the manual override and the pilot

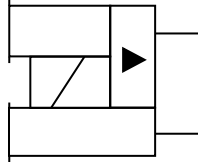

The solenoid and the pilot or a manual override and the pilot or a manual override alone.

8. Rotary Devices

8.1 Basic Symbol

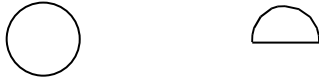

8.1.1 With Ports

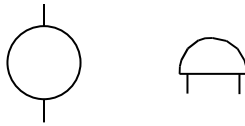

8.1.2 With Rotating Shaft, with control and with Drain

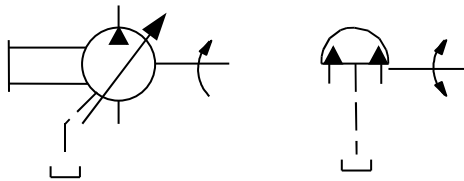

8.2 Hydraulic Pump

8.2.1 Fixed Displacement

8.2.1.1 Unidirectional

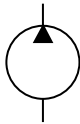

8.2.1.2 Bidirectional

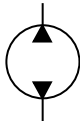

8.2.2 Variable Displacement, Non-compensated

8.2.2.1 Unidirectional

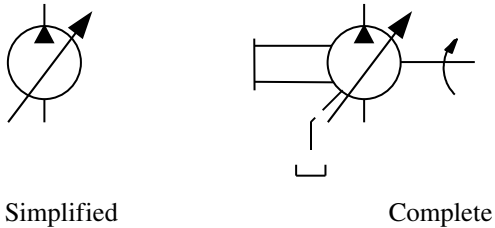

8.2.2.2 Bidirectional

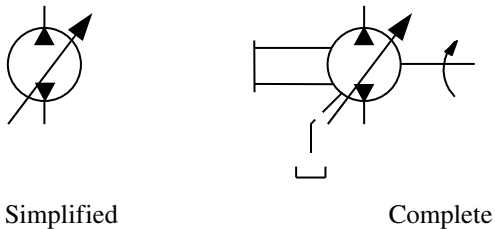

8.2.3 Variable Displacement, Pressure Compensated

8.2.3.1 Unidirectional

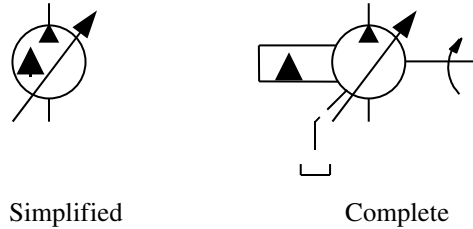

8.2.3.2 Bidirectional

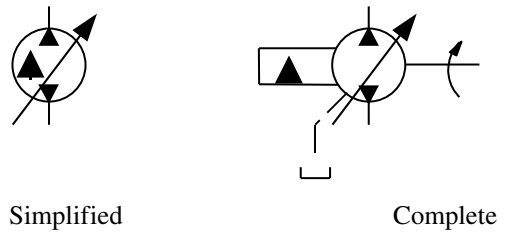

8.3 Hydraulic Motor

8.3.1 Fixed Displacement

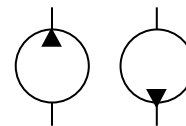

8.3.1.2 Bidirectional



8.3.2 Variable Displacement

8.3.2.1 Unidirectional

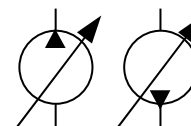

8.3.2.2 Bidirectional



8.4 Pump – Motor, Hydraulic

8.4.1 Operating in one direction as a pump. Operating in the other direction as a motor.

8.4.1.1 Complete Symbol

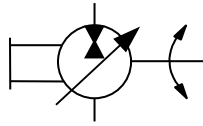

8.4.1.2 Simplified Symbol



8.4.2 Operating one direction of flow as either a pump or as a motor.

8.4.2.1 Complete Symbol

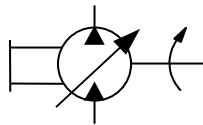

8.4.2.2 Simplified Symbol



8.4.3 Operating in both directions of flow either as a pump or as a motor. (Variable displacement, pressure compensated shown.)

8.4.3.1 Complete Symbol

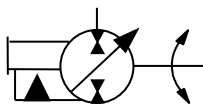

8.4.3.2 Simplified Symbol



8.5 Pump Pneumatic

8.5.1 Compressor, Fixed Displacement

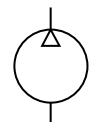

8.5.2 Vacuum Pump, Fixed Displacement

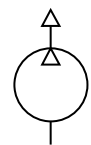

8.6 Motor, Pneumatic

8.6.1 Unidirectional

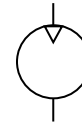

8.6.2 Bidirectional

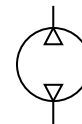

8.7 Oscillator

8.7.1 Hydraulic



8.7.2 Pneumatic



8.8 Motors, Engines

8.8.1 Electric Motor



8.8.2 Heat Engine (E.G. internal combustion engine.)



9. Instruments and Accessories

9.1 Indicating and Recording

9.1.1 Pressure

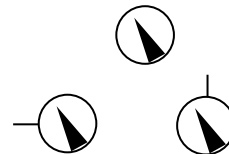

9.1.2 Temperature

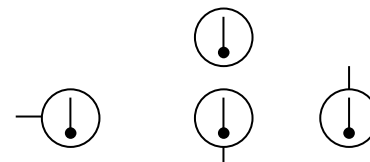

9.1.3 Flow Meter

9.1.3.1 Flow Rate

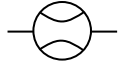

9.1.3.2 Totalizing

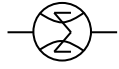

9.2 Sensing

9.2.1 Venturi

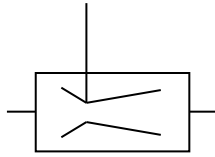

9.2.2 Orifice Plate



9.2.3 Pitot Tube

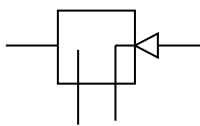

9.2.4 Nozzle

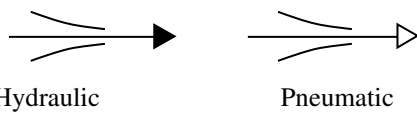

Hydraulic

Pneumatic

9.3 Accessories

9.3.1 Pressure Switch

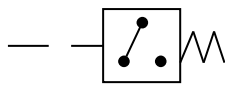

9.3.2 Muffler



10. Valves

A basic valve symbol is composed of one or more envelopes with lines inside the envelope to represent flow paths and flow conditioners between ports. Three symbol systems are used to represent valve types: single envelope, both finite and infinite position; multiple envelope, finite position; and multiple envelope, infinite position.

10.1 In infinite position single envelope valves, the envelope is imagined to move to illustrate how pressure or flow conditions are controlled as the valve is actuated.

10.2 Multiple envelopes symbolize valves providing more than one finite flow path option for the fluid. The multiple envelope moves to represent how flow paths change when the valving element within the component is shifted to its finite positions.

10.3 Multiple envelope valves capable of infinite positioning between certain limits are symbolized as in 10.2 above with the addition of horizontal bars, which are drawn parallel to the envelope. The horizontal bars are the clues to the infinite positioning function possessed by the valve represented.

10.4 Envelopes

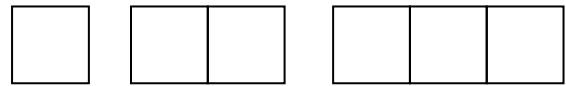

10.5 Ports

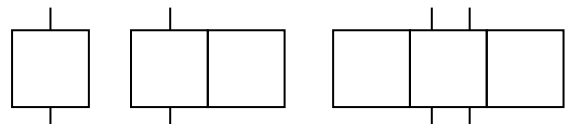

10.6 Ports, Internally Blocked

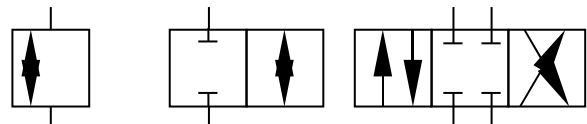

Symbol System 10.1

Symbol System 10.2

10.7 Flow Paths, Internally Open (Symbol System 10.1 and 10.2)

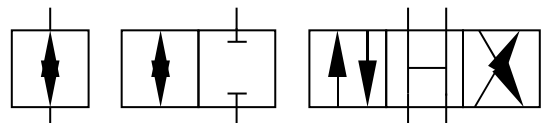

Symbol System 10.1

Symbol System 10.2

10.8 Flow Paths, Internally Open (Symbol System 10.3)

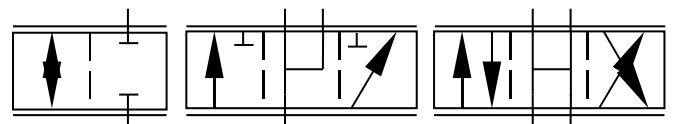

10.9 Two-Way Valves (2 Ported Valves)

10.9.1 On-Off (Manual Shut Off)

Simplified



Off

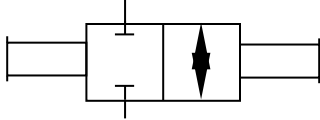

On

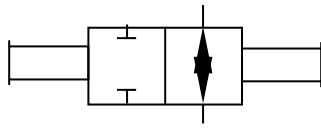

10.92 Check

Simplified

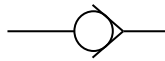

Composite Symbol. Flow to the right is blocked. Flow to the left is permitted.

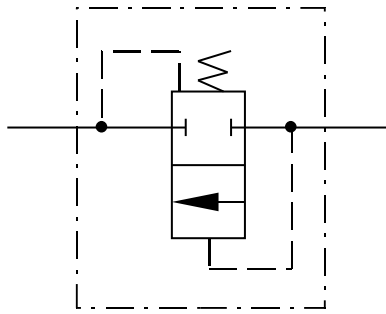

10.93 Check, Pilot-Operated to Open

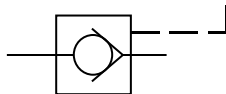

10.94 Check, Pilot-Operated to Close

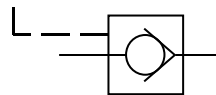

10.9.5 Two-Way Valves

10.9.5.1 Two-Position

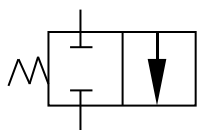

Normally Closed

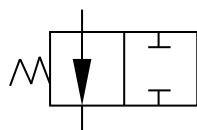

Normally Open

10.9.5.2 Infinite Position

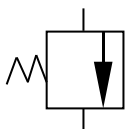

Normally Closed

Normally Closed

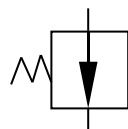

Normally Open

Normally Open

10.10 Three-Way Valves

10.10.1 Two Position

10.10.1.1 Normally Open

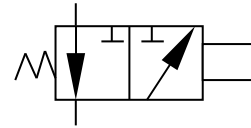

10.10.1.2 Normally Closed

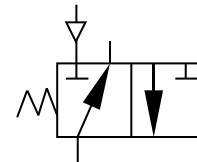

10.10.1.3 (Distributor Pressure is distributed first to one port, then the other).

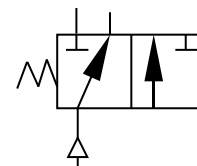

10.10.1.4 Two-Pressure

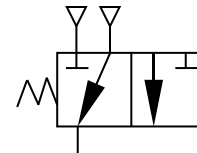

10.10.2 Double Check Valve – Double check valves can be built with and without “cross bleed”. Such valves with two poppets do not usually allow pressure to momentarily “cross bleed” to return during transition. Valves with one poppet may allow “cross bleed” as these symbols illustrate.

10.10.2.1 Without Cross Bleed (One way flow).

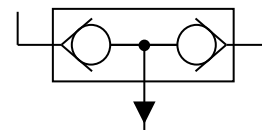

10.10.2.2 With Cross Bleed (Reverse flow permitted).

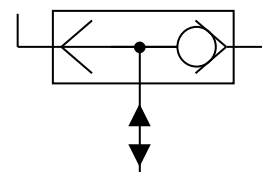

10.11 Four-Way Valves

10.11.1 Two-Position

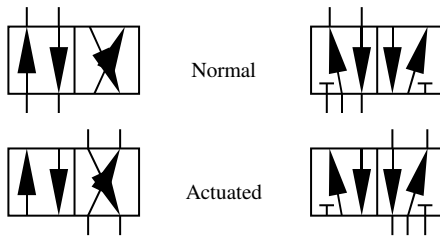

10.11.2 Three Position

(a) Normal

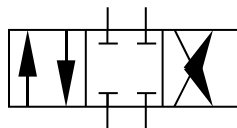

(b) Actuated Left

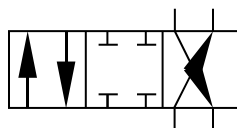

(c) Actuated Right

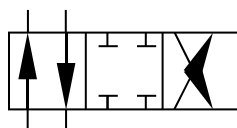

10.11.3 Typical Flow Paths for Center Condition of Three-Position Valves

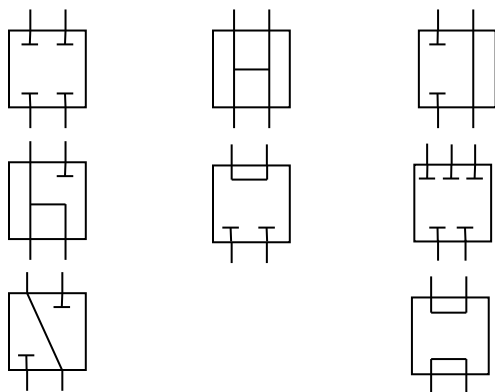

10.11.4 Two-Position, Snap Action with Transition.

As the valve element shifts from one position to the other, it passes through an intermediate position. If it is essential to circuit function to symbolize this “in transit” condition, it can be shown in the center position, enclosed by dashed lines.



Typical Transition Symbol

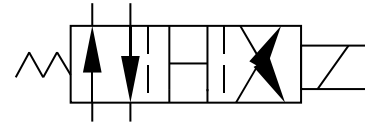

10.12 Infinite Positioning (between open and closed)

10.12.1 Normally Closed

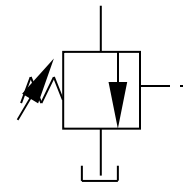

10.12.2 Normally Open

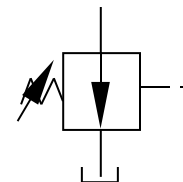

10.13 Pressure Control Valves

10.13.1 Pressure Relief

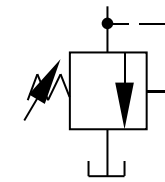

Simplified Symbol

Denotes

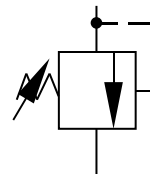

Normal

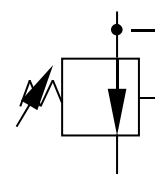

Actuated
(Relieving)

10.13.2 Sequence

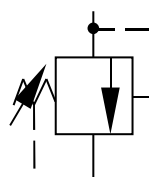
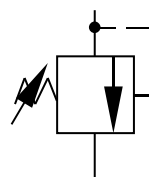

10.13.3 Pressure Reducing

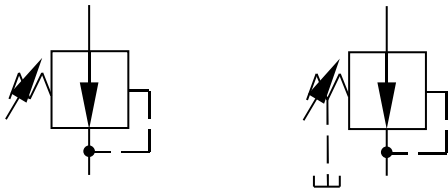

10.13.4 Pressure Reducing and Relieving

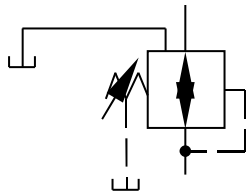

10.13.5 Airline Pressure Regulator (Adjustable, Relieving)

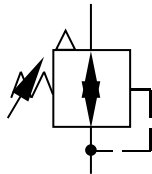

10.14 Infinite Positioning Three-Way Valves

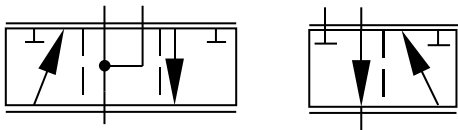
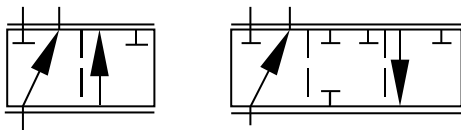

10.15 Infinite Positioning Four-Way Valves

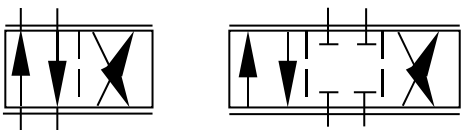

10.16 Flow Control Valves (See 3.7)

10.16.1 Adjustable, Non-Compensated (Flow control in each direction)



10.16.2 Adjustable with Bypass

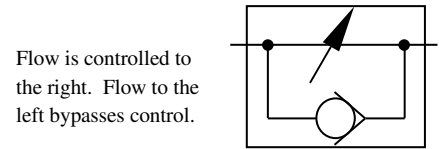

10.16.3 Adjustable and Pressure Compensated with Bypass

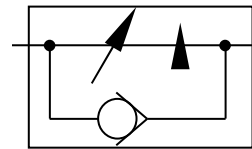

10.16.4 Adjustable, Temperature and Pressure Compensated

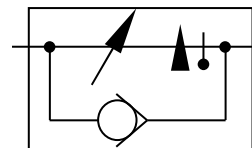

11. Representative Composite Symbols

11.1 Component Enclosure



Component enclosure may surround a complete symbol or a group of symbols to represent an assembly. It is used to convey more information about component connections and functions. Enclosure indicates extremity of component or assembly. External ports are assumed to be on enclosure line and indicate connections to component.

Flow lines shall cross enclosure line without loops or dots.

11.2 Airline Accessories (Filter, Regulator and Lubricator)

Composite

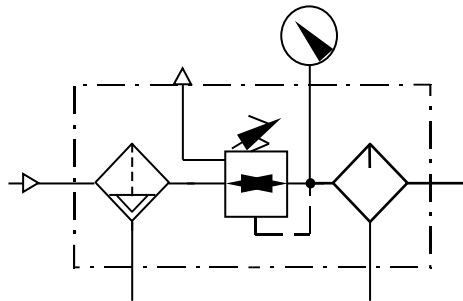

Simplified

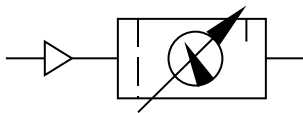

11.3 Pumps and Motors

11.3.1 Pumps

11.3.1.1 Double, Fixed Displacement, One Inlet and Two Outlets.

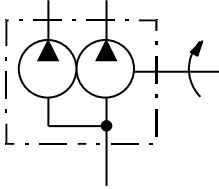

11.3.1.2 Double, with Integral Check Unloading and Two Outlets

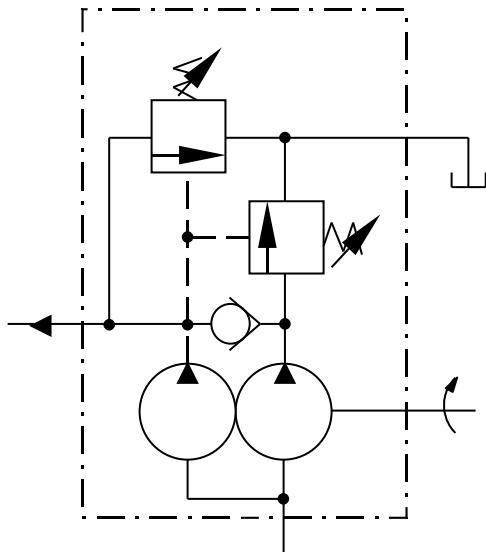

11.3.1.3 Integral Variable Flow Rate Control with Overload Relief

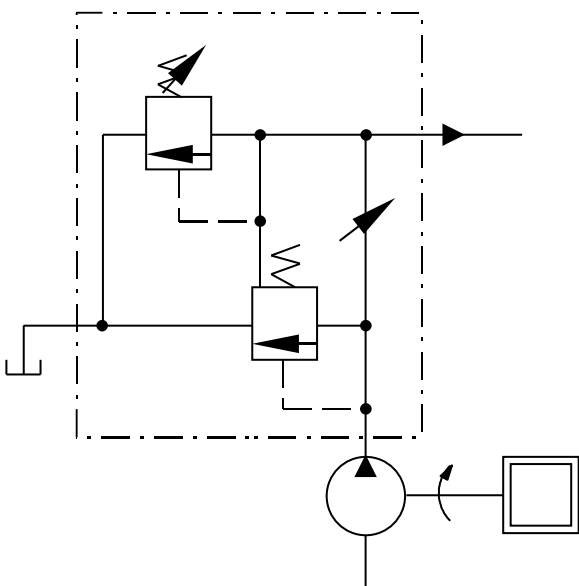

11.3.1.4 Variable Displacement with Integral Replenishing Pump and Control Valves

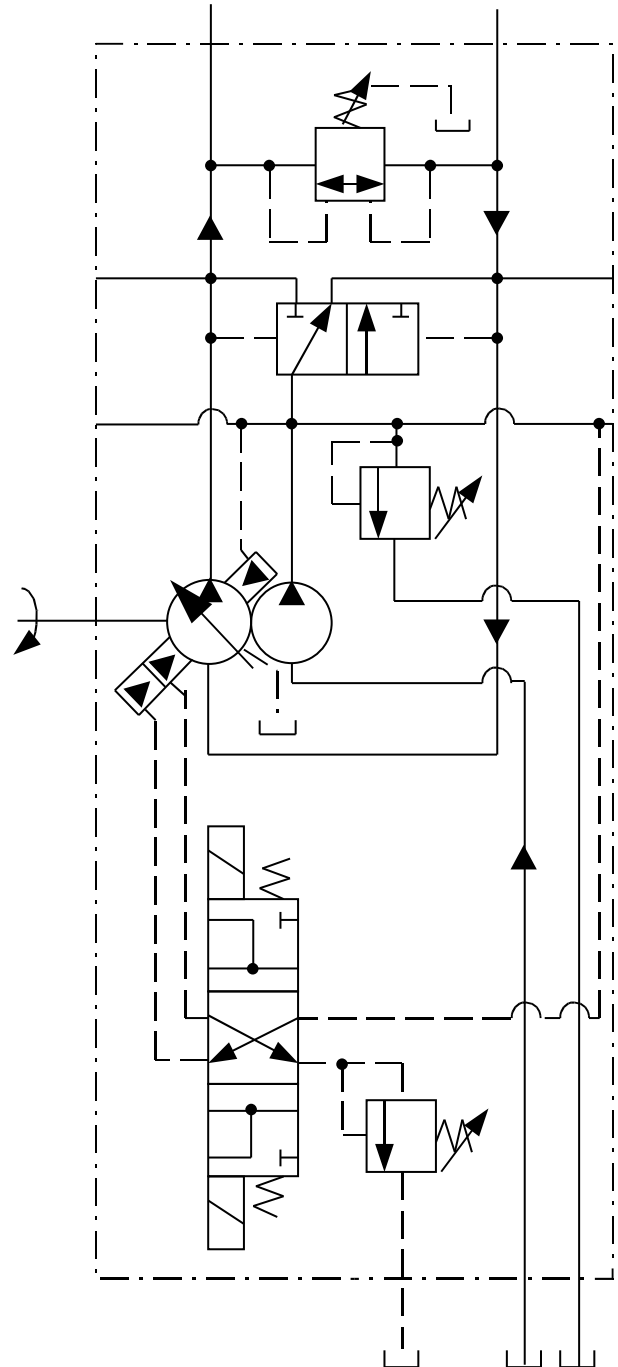

11.4.6 Two-Positions, Four Connection Solenoid, and Pilot Actuated, with Manual Pilot Override.

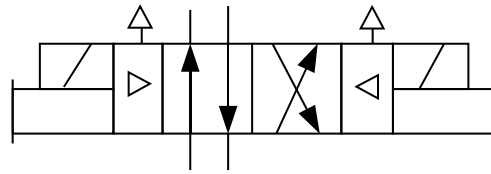

Simplified Symbol

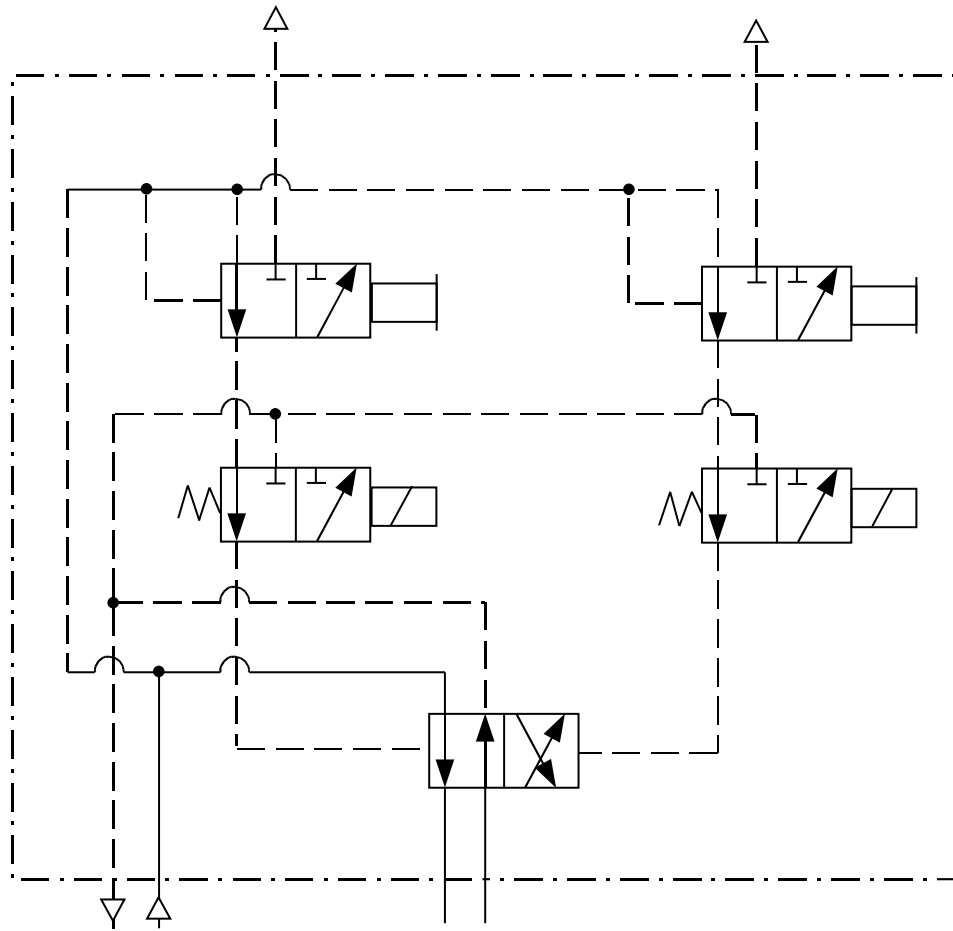

Complete Symbol

11.4 Valves

11.4.1 Relief, Balanced Type

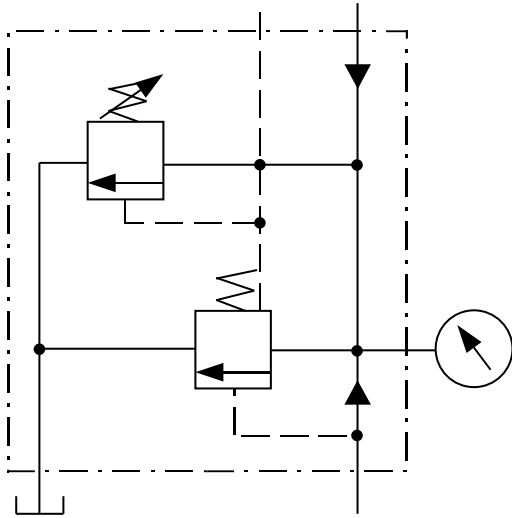

11.4.2 Remote Operated Sequence with Integral Check

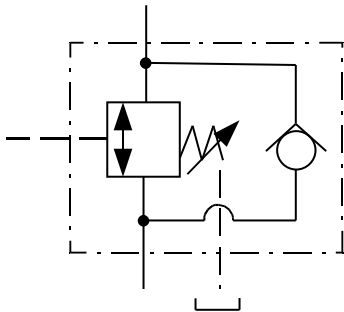

11.4.3 Remote and Direct Operated Sequence with Differential areas and Integral Check.

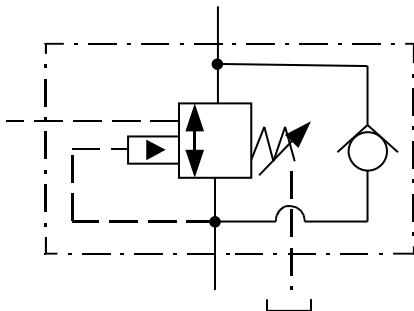

11.4.4 Pressure Reducing with Integral Check.

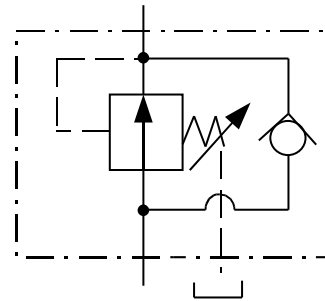

11.4.5 Pilot Operated Check

11.4.5.1 Differential Pilot Operated.

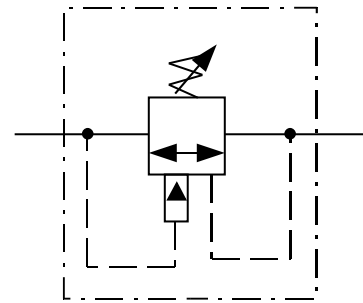

11.4.5.2

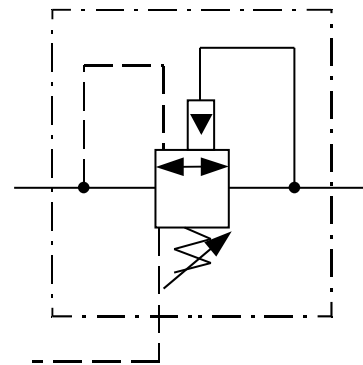

11.4.7 Two-Position, Five Connection, Solenoid Control Pilot Actuated with Detents and Throttle Exhaust.

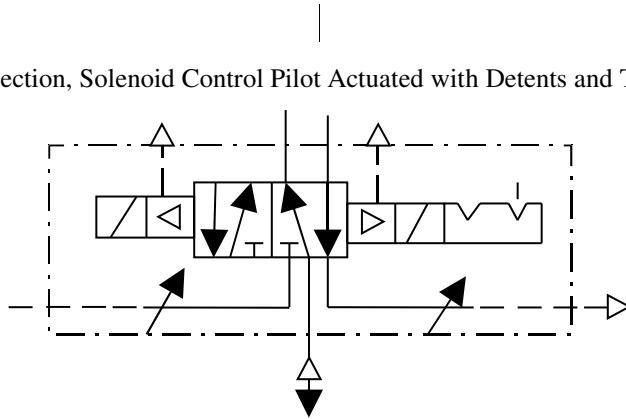

Simplified Symbol

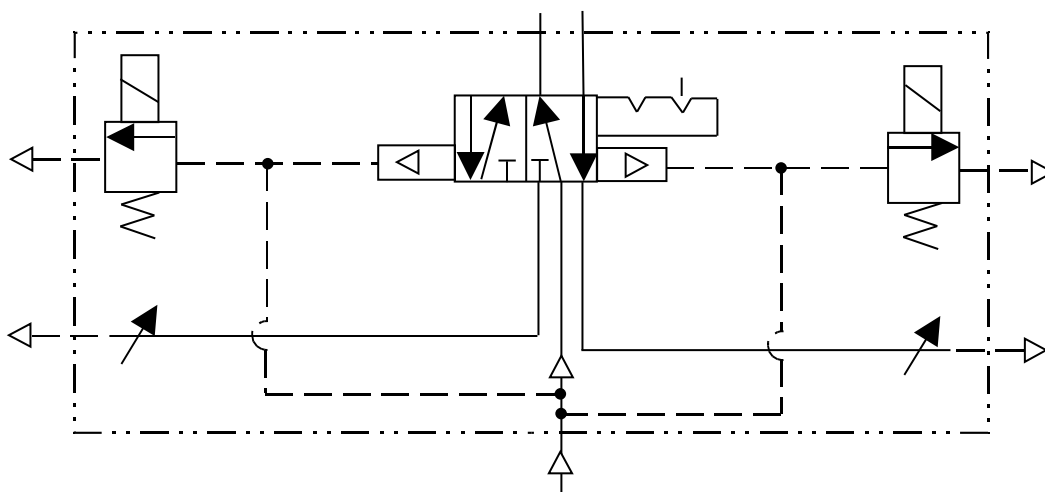

Complete Symbol

11.4.8 Variable Pressure Compensated Flow Control and Overload Relief.

